



John Berends Implements Pty Ltd

AGRICULTURAL ENGINEERS

OPERATOR'S MANUAL PARTS LIST



Rotary Drain Diggers

PRODUCT NO.

0145
0146

Rotary Drain Digger
Rotary Drain Digger c/w Rippers

130 FRANKSTON-DANDENONG RD, DANDENONG SOUTH, VIC. 3175 AUSTRALIA
PHONE (03) 9791 2494 FAX NO. (03) 9794 5568
www.johnberendsimplements.com.au

TABLE OF CONTENTS

Page No.

SAFETY INSTRUCTIONS.....	3
SAFETY FEATURES.....	6
ASSEMBLY.....	7
OPERATION.....	7
MAINTENANCE.....	8
SPARE PARTS.....	10





SAFETY





Farm machinery is dangerous if operated incorrectly so please read this manual in its entirety prior to operating the machine.

 No operator, however experienced in farm machinery operation, should attempt to use any machine they have not been competently trained to use. Your local Department of Agriculture can help you with training, as can most Occupational Health and Safety offices, Agricultural schools and colleges and farm equipment dealerships.

 All instructions relating to tractor safety as per the tractor operators manual should be followed. When making any machine adjustments, stop the tractor engine first and wait for all moving parts to stop. Maintain the tractor to ensure it remains safe to use. Do not operate faulty or damaged equipment.

 Extreme caution should be taken when fitting equipment to the tractor's three point linkage. Avoid standing between the implement and the tractor when coupling machinery.

 All machines should be mounted and retained correctly. All guards must be kept in place and correctly maintained. P.T.O. shafts must be correctly attached and secured to both the tractor and the machine. Decals must be visible and legible at all times. Keep well clear of all moving parts.

 Keep all people and animals at a safe distance from all moving parts. Children must not be allowed to operate this equipment and all passengers must have the same level of protection as the operator.

 Wear protective clothing where appropriate.

 Never operate when tired (not alert) or in poorly lit areas and stay alert for humps and other hidden hazards. Remove all timber, rocks and foreign objects prior to operation.

 Avoid operating the machine in wet conditions.

 Exercise extreme caution when changing direction on hills. Avoid sudden movement, sudden breaking, high speeds, rough terrain and steep slopes.

 If machine starts to vibrate, stop tractor using method as described in the operation section.

 After striking a foreign object or if there are doubts about the performance of the machine, stop the tractor as described and check if machine is making excessive noise.

 Extreme caution must be taken when working in public areas (roadsides etc). It is recommended that flaps and chains are fitted in these areas. These are available as optional extras. Rear flaps are compulsory in public areas.

 Do not modify this equipment in anyway, or use it for any other purpose than it was designed to do.

 Never work under unsupported machines or adjust unsupported machines. Do not enter the danger zone where a load being carried by a machine could fall on you, for example a round bale from a bale fork, a log from a carryall or material from a rear end loader.

These instructions should be used in conjunction with any local regulations regarding safety ie OHS.

Maintenance is essential for safe operation. Ensure maintenance is carried out regularly by people qualified to do so. This is of particular importance on P.T.O. drive machines where driven parts can fly off at high speed if wearing parts are not properly maintained.

FAILURE TO FOLLOW THESE INSTRUCTIONS AND PROCEDURES MAY RESULT IN EQUIPMENT MALFUNCTION, OR DAMAGE, SERIOUS INJURY OR EVEN DEATH.

INTRODUCTION:

This manual was developed specifically for the machine you have purchased. The information within is to assist you in preparing, operating and maintaining your machine. Please read and understand the contents of the manual completely before attempting to operate your machine, paying special attention to all safety details. With our policy of continuous improvement, products and specifications may change without notice and without incurring the obligation to install such changes on any unit previously delivered.

Rotary Drain Diggers

The Berends rotary drain digger is of heavy duty construction and is fitted with a heavy duty p.t.o. and slip clutch as standard. The digger blades are made of 10mm very high tensile steel and are all set at the best angle possible for drain digging. The machine is fitted with an adjustable foot which can be controlled from the tractor. The foot has a skid on it which ensures an even depth is maintained. An adjustable windrow shield is fitted as standard. The Berends rotary drain digger is capable of digging depths of 24" and a width of 28". Rippers are available as an option and these help especially where the ground is hard and the tractor has good draft ability as well as p.t.o. power.

MACHINE SPECIFICATIONS

MODEL	Rotary Drain Digger
Cutting Width	28"
Cutting Depth	24"
Blade Thickness	10mm
Tractor H.P.	50-80 H.P.
Tractor CAT connection	Cat 1/2
Nett Weight (kg) without rippers	210

WARRANTY

John Berends Implements P/L warrants each new product sold to be free from defects in material and workmanship, under normal use and service, as outlined in the operator's manual, for a period of 12 months. This warranty is void if any damage to the machine has been caused by misuse or non genuine parts have been used or any repairs have been made by any persons other than authorised dealer service personnel. The manufacturer/dealer is not obligated to any transportation charges incurred in the repair or replacement of parts. This warranty does not exclude any condition or warranty implied by the Trade Practices Act 1974 or any other legislation which implies any condition which cannot be excluded.

© Copyright 1998 This Safety Manual is copyright and no part may be reproduced without the written permission of John Berends Implements.

Safety Features

1. SERIAL NUMBER (Decal)



2. WARNING DECAL



3. CAUTION DECAL

**CAUTION
KEEP CLEAR OF
MOVING PARTS**

4. BERENDS DECAL

5. CLUTCH COVER GUARD

6. P.T.O. SHAFT INNER/OUTER GUARDS

7. WINDROW SHIELD

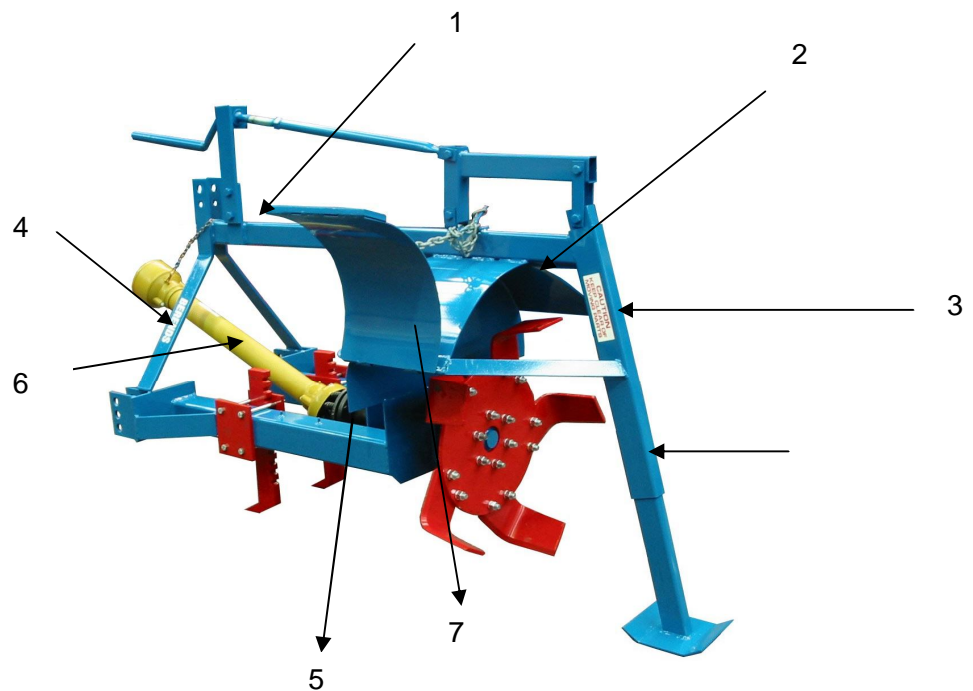

ASSEMBLY

Line up the lower linkage arms with the linkage pins of the drain digger, slide the linkage arms onto the pins and secure with lynch pins. Attach the top link to the digger in such a manner that the digger remains as close as possible to horizontal position when working.

Fitting and removal of the P.T.O. shaft

The P.T.O. shaft can be fitted or removed by depressing the quick release pins at each end. To avoid difficulties later it is advisable to apply some grease to the input shaft prior to fitting the P.T.O. shaft.

OPERATION

Once all safety procedures have been followed, start the tractor and raise the digger sufficiently so that the blades clear the ground. Adjust the skid (which regulates the depth of the cut) as required. To adjust the skid it will be necessary to have the weight off the skid at all times. To ease adjustment it is recommended that the rectangular tube receives some lubrication

When the machine is ready for work and the operator seated on the tractor, engage the P.T.O. and lower the linkage. Do not select too high a gear at first as it puts undue strain on tractor, digger and operator. You will soon find the right selection for your condition. When using the machine ensure the speed is always kept at 540 rpm.



Caution:

If working near buildings, roads or neighbouring properties, use the guard to control dirt or stones. If necessary, this guard is adjustable through use of the chain. It is recommended to travel into the wind on very windy days so as to protect the tractor driver. If the operator is not certain of the condition of the area to be dug, a prior inspection is recommended, particularly as vacant blocks, sides of roads and channels can hold hazardous surprises. Remove all timber, rocks and foreign objects.

If the digging is extremely heavy and the tractor has difficulty handling it, take a shallow cut which requires less horsepower. When cutting a new drain, in an effort to keep it straight, make a pre-determined track aiming for a distant point like a fence post or tree. If backfilling is required, use the guard to windrow the soil along the drain, the soil can then be easily pushed back with a grader blade. Do not work the implement while the P.T.O. is sharply angled (For example. - digging through a bank) as this puts a heavy strain on the shaft, resulting in damage.

Stopping

Slow engine speed to idle and disengage P.T.O. shaft. Lower the machine, stop the tractor engine (removing the ignition key) and apply the park brake.



Caution:

Before disengaging the P.T.O., reduce the rpm so as to prevent damage to the shaft.

MAINTENANCE

When doing any type of maintenance on this machine, always follow the safety steps described in this manual. Service should only be carried out by qualified personnel. Use only authorised genuine parts for replacement.

The rotary drain digger must be adequately supported under its body. (Make certain it cannot fall). After initial use check tightness of blade bolts, clutch retaining bolts (if fitted) and bearing bolts and tighten if necessary. Grease skid slide as required.

Bearings

To replace bearings it is necessary to remove the clutch. Lock the rotor by putting a piece of timber or pipe through the blades. Remove the nut from the shaft, loosen the set screws in the bearings (2 in each bearing) and pull out rotor. The bearing housing can then be removed and bearings replaced.

Blades

Replace blades with genuine drain digger blades, rotary drain digger blades are not satisfactory due to a different angle of attack. When replacing blade bolts, do not use high tensile bolts, as this can result in putting more strain on the bearings etc. when hitting hard obstacles.

Power take off (P.T.O.) shaft

Before operating the machine, check that the P.T.O. shaft is securely attached to the tractor and to the digger.

Confirm the minimum and maximum working lengths of the P.T.O. shaft. The telescopic tubes must be overlapping at least 150mm. If it is necessary to shorten the shaft, contact your implement dealer.

Check that the tube guards are not damaged and rotate freely on the P.T.O. shaft. Safety chains must be sufficiently loose to allow free turning of the tube guards.

Check that the angle of the joints on the P.T.O. shaft do not exceed 35 degrees.

When machine is not in use, protect or cover the P.T.O. shaft from the weather.

Check all components are fully lubricated before use. Frequently grease all points as shown in Figure 1.

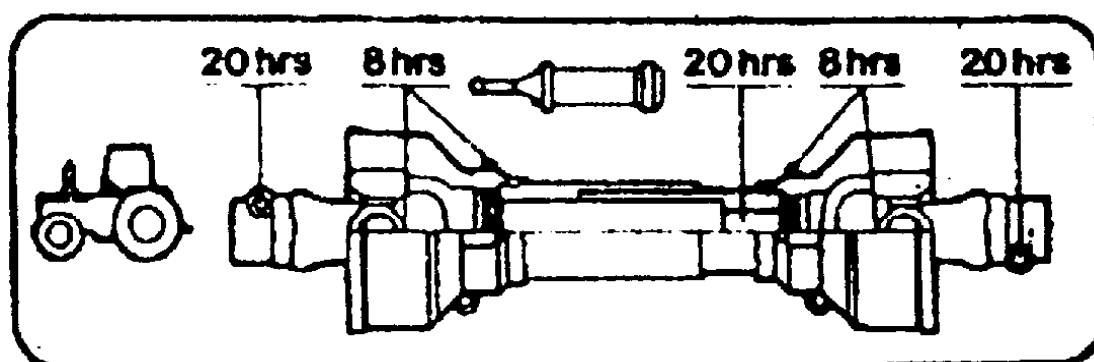
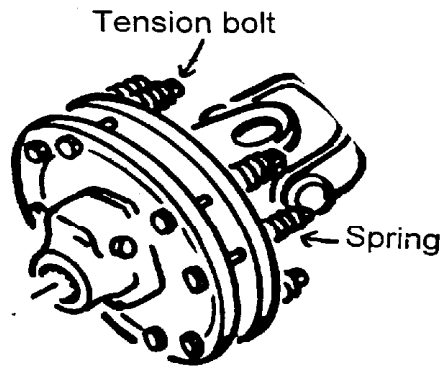

FIGURE 1. : Grease points and intervals for P.T.O. shaft.

Slip clutch setting



Slip Clutches need to be set if one of the following occurs:

The clutch has been repaired (including replacing the friction discs).

The clutch is slipping in work (clutch getting hot, burning out friction discs, machine slowing down in work).

The clutch not slipping when the machine hits an obstruction (tractor stalls, P.T.O. breaks).

The clutch has been freed up after a period of storage (see "how to free up clutch" next page).

How to set the clutch

The setting of the clutch is dependent on many variables - the work, the size of the tractor, the size of the machine and so on. It is best to set each clutch individually if possible. The aim is to start with a loose clutch and tighten it up to the exact point where it stops slipping in normal work. If set in this way the clutch will slip if any load exceeds this point, protecting both tractor and machine. It is best to set up the clutch with the machine on the tractor which will normally be used, and in conditions which approximate to the normal work the machine does. The bolts which go through the springs and hold tension on the clutch determine the point at which the clutch slips. These must all be set evenly, either by measuring spring length or counting the number of turns the nut has been tightened. The clutch must be quite loose initially to ensure it will slip. Slipping can be identified by the clutch getting very hot. The clutch will always be quite warm in work as the gearbox gets warm. Run the machine for a short distance (20 metres) in work and check the clutch slips. Then tighten each tension bolt up a turn (more if the clutch was very loose) evenly and run a short distance again. Keep repeating this procedure until the clutch is not slipping - it should only take a few stops. As you get to the point at which the clutch is not slipping tighten the tension bolts half a turn instead of a full turn.

Never tighten the clutch beyond one full turn out from fully tightened (springs coil-bound), or the clutch will not operate as a clutch and will fail to protect the machine. If the clutch still slips when you get to one turn out from coil-bound *reduce the load*. Reduce your ground-speed or take less cut. Otherwise you risk damaging the machine. *Whenever a slip clutch slips take all load off it until full operating speed is regained with zero load. Continuing to operate with a slipping clutch will result in clutch damage.* Continue to work the machine checking the clutch regularly to see how it is performing. You may want to adjust it for varying conditions. If the clutch is too loose it will slip, wearing out the friction discs, getting hot and possibly damaging the clutch pressure surfaces as well. Remember as the plates wear, the tension on them is reduced. If the clutch is too tight it will fail to protect the tractor and machine when an overload occurs.

How to free up the clutch after a period of storage

Slip clutches can seize up if left for long periods without use. To free up the clutch loosen all the tension bolts until the springs are free of any tension. Then run the machine into normal work so the clutch slips. With the clutch set in this way the machine will fail to work at all, clutch slip being 100%. Run the machine in this way for 30 seconds to one minute. This cleans the surfaces of the clutch. An alternative to this is dismantling the clutch and cleaning it.

SPARE PARTS

ORDER SPARE PARTS THROUGH YOUR ORIGINAL SUPPLIER OR YOUR LOCAL JOHN BERENDS IMPLEMENTS DEALER.

Always quote the machine serial No. or product No., spare part number and its part name as stated in the operator's manual.

Rotary drain diggers (0145/0146)

Key No.	Part No.	Quantity	Description
1	1994	5	Rotary drain digger blade
2	1954	10	Bolt/nut/sw suit blade
3	1955	6	Bolt/nut/sw suit rotor centre disc
4	1996	1	Rotor centre disc
5	1626	1	Main shaft (6 spline)
	1624	1	Main shaft (keyway) used prior to 1980
6	1628	2	Main bearing 2"
7	1930	2	Bearing housing
8	1957	1	Nut suit 1626 main shaft
	1990	1	Nut suit 1624 main shaft
9	3907	1	Nut spacer suit main shaft
10	1991	1	Clutch cover (tin)
11	3029	1	P.T.O (refer diagram)
12	1969	2	Cat 1 push through pin
13	3918	1	Ripper kit (2 tine/wedges & clamp plates) - optional
14	1519	ar	Ripper only – optional

